

# Machining time reduction in shaping machine

S.MADAN, N.GANESAMOORTHY, M.KARTHIKEYAN, M.MAHENDRAN, AND K.ARUNKUMAR

**Abstract**— Shaper is used to machine a single job by using a single point cutting tool and hence it cannot be used for high production rates. This project intends to use shaper for high production as well. A small skeleton structure has been thus devised to demonstrate the machining time reduction in shaping machines. The shaping machine has an idle stroke during its return motion. This project is uses the idle stroke as cutting stroke and hence increase the production rate. This can be achieved by an addition of clapper box with a tool such that the arrangement on tool holder has one tool clamped on the clapper box individually. This stroke would be a rough cutting stroke for the job, compared to the forward stroke. The pneumatic source of power with control accessories is used to drive the ram or the cylinder piston to obtain the forward and return strokes. By this arrangement the machining time of a work piece is reduced by half the time when compared with the conventional machines.

**Keywords**— Pneumatic cylinder, Solidworks, Electronic Control unit

## S I. INTRODUCTION

Shaper is a type of machine tool that uses linear relative motion between the work piece and a single-point cutting tool to machine a linear tool path. A shaping machine is also called shaper is mainly used for producing flat surfaces, which may be horizontal, vertical or inclined. Sometimes curved or irregular surfaces are also produced by shapers. Shapers were very common in industrial production from the mid-19th century through the mid-20th. In current industrial practice, shapers have been largely superseded by other machine tools, including milling machines, grinding machines, and broaching machines. But the basic function of a shaper is still sound tooling for them is minimal and very cheap to reproduce; and they are simple and robust in construction, making their repair and upkeep easily achievable. In shaping machines the stroke length can be varied by changing the distance between center of the bull gear and pivot pin. In shaping machine the vertical slots are provide on one side of the shaping machine. The slots can be used to move vertically (upwards or downwards) the bull gear position. In a shaper rotary movement of the drive is converted into reciprocating movement by the mechanism contained within the column or frame of the machine. The ram holding the tool gets the reciprocating movement. In a standard shaper metal is removed in the forward cutting stroke, while the return stroke goes idle and no metal is removed during this period. In our project TIME REDUCTION IN PNEUMATIC SHAPING MACHINE time is considered to be the main criteria.

## II. MANUFACTURING PROCESS

Manufacturing processes are the steps through which raw materials are transformed into a final product. The manufacturing process begins with the creation of the materials from which the design is made. These materials are then modified through manufacturing processes to become the required part. Manufacturing processes can include treating machining, or reshaping the material. The manufacturing process also includes tests and checks for quality assurance during or after the manufacturing, and planning the production process prior to manufacture

### A. Metal cutting:

Metal cutting or machining is the process of by removing unwanted material from a block of metal in the form of chips. Cutting processes work by causing fracture of the material that is processed. Usually, the portion that is fractured away is in small

sized pieces, called chips. Common cutting processes include sawing, shaping (or planing), broaching, drilling, grinding, turning and milling. Although the actual machines, tools and processes for cutting look very different from each other, the basic mechanism for causing the fracture can be understood by just a simple model called for orthogonal cutting. In all machining processes, the work piece is a shape that can entirely cover the final part shape. The objective is to cut away the excess material and obtain the final part. This cutting usually requires to be completed in several A the exposed portion can be accessed by the tool to machine in that portion. Common fixtures include vise, clamps, 3-jaw or 4-jaw chucks, etc. Each position of holding the part is called a setup. One or more cutting operation may be performed, using one or more cutting tools, in each setup. To switch from one setup to the next, we must release

E

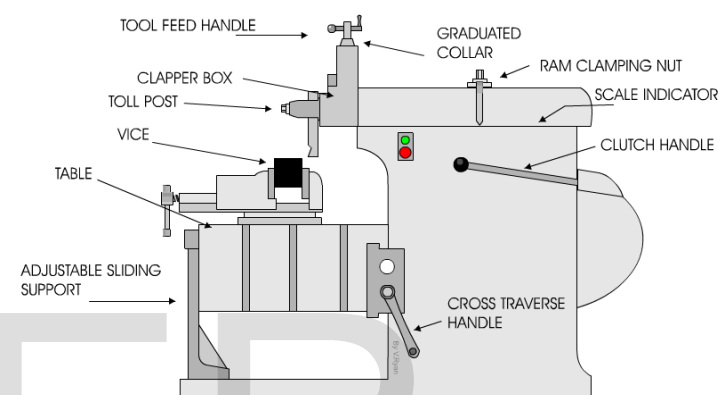

the part from the previous fixture, change the fixture on the machine, clamp the part in the new position on the new fixture, set the coordinates of the machine tool with respect to the new location of the part, and finally start the machining operations for this setup. Therefore, setup changes are time-consuming and expensive, and so we should try to do the entire cutting process in a minimum number of setups; the task of determining the sequence of the individual operations, grouping them into (a minimum number of) setups, and determination of the fixture used for each setup, is called process planning.

These notes will be organized in three sections:

- (i) Introduction to the processes,
- (ii) The orthogonal cutting model and tool life optimization and
- (iii) Process planning and machining planning for milling.

### B. Sawing:

Cold saws are saws that make use of a circular saw blade to cut through various types of metal, including sheet metal. The name of the saw has to do with the action that takes place during the cutting process, which manages to keep both the metal and the blade from becoming too hot. A cold saw is powered with electricity and is usually a stationary type of saw machine rather than a portable type of saw. The circular saw blades used with a cold saw are often constructed of high speed steel. Steel blades of this type are resistant to wear even under daily usage. The end result is that it is possible to complete a number of cutting projects before there is a need to replace the blade. High speed steel blades are especially useful when the saws are used for cutting through thicker sections of metal. Along with the high speed steel blades, a cold saw may also be equipped with a blade that is tipped with tungsten

carbide. This type of blade construction also helps to resist wear and tear. One major difference is that tungsten tipped blades can be re-sharpened from time to time, extending the life of the blade. This type of blade is a good fit for use with sheet metal and other metallic components that are relatively thin in design.

### III. COMPONENTS AND DESCRIPTION

The major parts that are effectively employed in the design and the fabrication of the pneumatic machining time reduction in shaping machine are described below:

- Pneumatic cylinder,
- Solenoid valve,
- Flow control valve,
- Electronic control unit,
- Flexible hoses,
- Clapper box and dead weight arrangement,

Air compressor.

#### A. Pneumatic cylinder

Mechanization is broadly defined as the replacement of manual effort by mechanical power. Pneumatics is an attractive medium for low cost mechanization particularly for sequential or repetitive operations. Many factories and plants already have a compressed air system, which is capable of providing both the power or energy requirements and the control system (although equally pneumatic control systems may be economic and can be advantageously applied to other forms of power). The main advantages of an all-pneumatic system are usually economy and simplicity, the latter reducing maintenance to a low level. It can also have outstanding advantages in terms of safety.

#### B. Selection of pneumatics

Mechanization is broadly defined as the replacement of manual effort by mechanical power. Pneumatic is an attractive medium for low cost mechanization particularly for sequential (or) repetitive operations. Many factories and plants already have a compressed air system, which is capable of providing the power (or) energy requirements and the control system (although equally pneumatic control systems may be economic and can be advantageously applied to other forms of power). The main advantage of an all pneumatic system are usually economic and simplicity the latter reducing maintenance to a low level. It can also have outstanding advantages in terms of safety.

#### C. Production of compressed air

Pneumatic systems operate on a supply of compressed air, which must be made available, in sufficient quantity and pressure to suit the capacity of the system. When pneumatic system is being adopted for the first time, however it will indeed be necessary to deal with the question of compressed air supply. The key part of any facility for supply of compressed air is by means using reciprocating compressor. A compressor is a machine that takes in air, gas at a certain pressure and delivered the air at a high pressure. Compressor capacity is the actual quantity of air compressed and delivered and the volume expressed is that of the air at intake conditions namely at atmosphere pressure and normal ambient temperature. Clean condition of the suction air is one of the factors, which decides the life of a compressor. Warm and moist suction air will result in increased precipitation of condense from the compressed air. Cylinder is mainly classified into two types namely,

- Single acting cylinder.
- Double acting cylinder

#### D. Double acting pneumatic cylinder

The cylinder is a double acting cylinder one, which means that the air pressure (forward and backward). The air from the compressor is passed through the regulator which controls the pressure to required amount by adjusting its knob. A pressure gauge is attached to the regulator for showing the line pressure. Then the compressed air is passed through the directional control valve for supplying the air alternatively to either sides of the cylinder. Two hoses take the output of the directional control valve and they are attached to two ends of the cylinder by means of connectors. One of the outputs from the directional control valve is taken to the flow control valve from taken to the cylinder. An air cylinder is an operative device in which the state input energy of compressed air i.e. pneumatic power is converted in to mechanical output power, by reducing the pressure of the air to that of the atmosphere. A double acting cylinder is employed in control systems with the full pneumatic cushioning and it is essential when the cylinder itself is required to retard heavy messes. This can only be done at the end positions of the piston stock. In all intermediate position a separate externally mounted cushioning derive must be provided with the damping feature. The normal escape of air is out off by a cushioning piston before the end of the stock is required. As a result the sit in the cushioning chamber is again compressed since it cannot escape but slowly according to the setting made on reverses. The air freely enters the cylinder and the piston stokes in the other direction at full force and velocity

#### E. Single acting pneumatic cylinder

A single-acting cylinder in a reciprocating engine is a cylinder in which the working fluid acts on one side of the piston only. A single-acting cylinder relies on the load, springs, other cylinders, or the momentum of a flywheel, to push the piston back in the other direction. Single-acting cylinders are found in most kinds of reciprocating engine. They are almost universal in internal combustion engines (e.g. petrol and diesel engines) and are also used in many external combustion engines such as Stirling engines and some steam engines. They are also found in pumps and hydraulic rams.

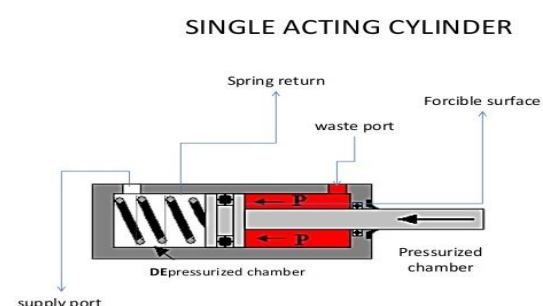

#### F. Solenoid valve

The directional valve is one of the important parts of a pneumatic system. Commonly known as DCV, this valve is used to control the direction of air flow in the pneumatic system. The directional valve does this by changing the position of its internal movable parts. This valve was selected for speedy operation and to reduce the manual effort and also for the modification of the machine into automatic machine by means of using a solenoid valve.



A solenoid is an electrical device that converts electrical energy into straight line motion and force. These are also used to operate a mechanical operation which in turn operates the valve mechanism. Solenoids may be push type or pull type. The push type solenoid is one in which the plunger is pushed when the solenoid is energized electrically. The pull type solenoid is one in which the plunger is pulled when the solenoid is energized.

The name of the parts of the solenoid should be learned so that they can be recognized when called upon to make repairs, to do service work or to install them.

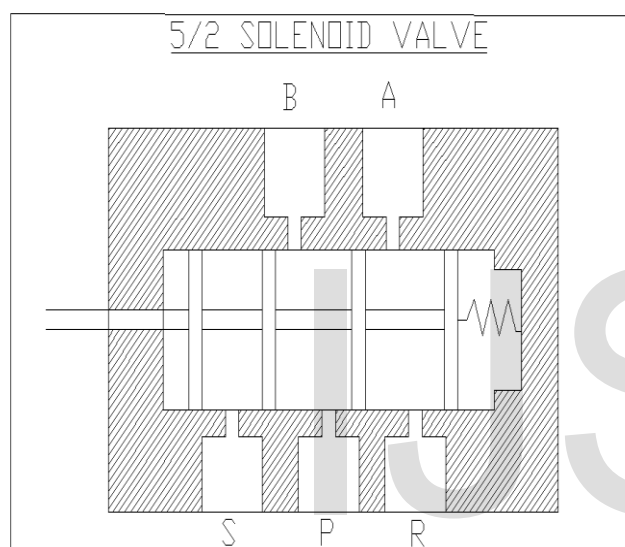

The solenoid valve has 5 openings. This ensure easy exhausting of 5/2 valve. The spool of the 5/2 valve slide inside the main bore according to spool position; the ports get connected and disconnected. The working principle is as follows.

**Position-1**

When the spool is actuated towards outer direction port ‘P’ gets connected to ‘B’ and ‘S’ remains closed while ‘A’ gets connected to ‘R’.

**Position-2**

When the spool is pushed in the inner direction port ‘P’ and ‘A’ gets connected to each other and ‘B’ to ‘S’ while port ‘R’ remains closed.

**G. Flow control valve**

A flow control valve regulates the flow or pressure of a fluid. Control valves normally respond to signals generated by independent devices such as flow meters or temperature gauges. Control valves are normally fitted with actuators and positioners. Pneumatically-actuated globe valves and Diaphragm Valves are widely used for control purposes in many industries, although quarter-turn types such as (modified) ball, gate and butterfly valves are also used.

Control valves can also work with hydraulic actuators (also known as hydraulic pilots). These types of valves are also known as Automatic Control Valves. The hydraulic actuators will respond to

changes of pressure or flow and will open/close the valve. Automatic Control Valves do not require an external power source, meaning that the fluid pressure is enough to open and close the valve. Automatic control valves include: pressure reducing valves, flow control valves, back-pressure sustaining valves, altitude valves, and relief valves. An altitude valve controls the level of a tank. The altitude valve will remain open while the tank is not full and it will close when the tanks reaches its maximum level. The opening and closing of the valve requires no external power source (electric, pneumatic, or man power), it is done automatically, hence its name. Process plants consist of hundreds, or even thousands, of control loops all networked together to produce a product to be offered for sale. Each of these control loops is designed to keep some important process variable such as pressure, flow, level, temperature, etc. within a required operating range to ensure the quality of the end product. Each of these loops receives and internally creates disturbances that detrimentally affect the process variable, and interaction from other loops in the network provides disturbances that influence the process variable.

**H. Electronic control unit**

In automotive electronics, Electronic Control Unit (ECU) is a generic term for any embedded system that controls one or more of the electrical system or subsystems in a motor vehicle. Types of ECU include Electronic/engine Control Module (ECM), Power train Control Module (PCM), Transmission Control Module (TCM), Brake Control Module (BCM or EBCM), Central Control Module (CCM), Central Timing Module (CTM), General Electronic Module (GEM), Body Control Module (BCM), Suspension Control Module (SCM), control unit, or control module. Taken together, these systems are sometimes referred to as the car's computer. Technically there is no single computer but multiple ones. Sometimes one assembly incorporates several of the individual control modules. Some modern motor vehicles have up to 80 ECUs. Embedded software in ECUs continues to increase in line count, complexity, and sophistication. Managing the increasing complexity and number of ECUs in a vehicle has become a key challenge for original equipment manufacturers (OEMs).In our project we use the control unit for controlling the DC motor that activates/deactivates the vehicle braking system. It is very simple in operation that, when the solenoid valve is connected to the electronic control unit the electronic control unit acts as the actuating device for the solenoid valve and it controls the flow direction of the air through the pneumatic cylinder.

**I. Flexible hoses**

Hose is fabricated in layer of elastomer or synthetic rubber and braided fabric, which permits operation at higher pressure. The standard tubing outside diameter is 1/16 inch. If the hose is subject to rubbing, it should be encased in a protective sleeve.

**J. Clapper box and dead weight arrangement**

The clapper box arrangement is fixed to the one end of the guide bush. The clapper box is having dead weight and tool feeding arrangement. The screw is used to feeding the depth of cut into the work piece.

**K. Air compressor**

An air compressor is a device that converts power (using an electric motor, diesel or gasoline engine, etc.) into potential energy stored in pressurized air (i.e., compressed air). By one of several methods, an air compressor forces more and more air into a storage tank, increasing the pressure. When tank pressure reaches its upper limit the air compressor shuts off. The compressed air, then, is held in the tank until called into use. The energy contained in the compressed air can be used for a variety of applications, utilizing the kinetic energy of the air as it is released and the tank depressurizes. When tank pressure reaches its lower limit, the air compressor turns on again and re-pressurizes the tank. There are

numerous methods of air compression, divided into either positive-displacement or negative-displacement types.

Due to adiabatic heating, air compressors require some method of disposing of waste heat. Generally this is some form of air- or water-cooling, although some (particularly rotary type) compressors may be cooled by oil (that is then in turn air- or water-cooled) and the atmospheric changes also considered during cooling of compressors.

The main function of the air compressor is to compress the air up to the required pressure. The maximum capacity of the compressor is  $10 \times 10^5$  to  $12 \times 10^5$  N/m<sup>2</sup>. This is a two stages or two-cylinder reciprocating air compressor. The two cylinders are for low and high compression. The air pressure is measured at various places by the use of pressure gauges. V-belt and pulley are used to drive the compressor.

Compressors can be broadly classified into two groups. They are:

- Positive Displacement Compressor
- Dynamic Compressors

#### A. Positive displacement compressor

Successive volumes of air isolated and then compressed to a higher pressure. There are essential two forms of positive displacement compressor, reciprocating and rotary.

#### B. Dynamic compressors

These are rotary continuous machines in which a high speed rotating element accelerates the air and converts the resulting velocity head into pressure. Positive displacement compressors work on the principle of increasing the pressure of a definite volume in an enclosed chamber. Dynamic (turbo) compressor employs rotating vanes or impellers to impart velocity and pressure to the flow of the air being handled. The pressure comes from the dynamic effects such

as centrifugal force.

### IV. WORKING PRINCIPLE

Initially starting with air compresses, its function is to compress air from a low inlet pressure (usually atmospheric) to a higher pressure level. This is accomplished by reducing the volume of the air.

Air compressors are generally positive displacement units and are either of the reciprocating piston type or the rotary screw or rotary vane types. The air compressor used here is a typically small sized, two-stage compressor unit. It also consists of a compressed air tank, electric rotor and pulley drive, pressure controls and instruments for quick hook up and use. The pressure exceeds the designed pressure of the receiver a release valve provided releases the excess air and thus stays a head of any hazards to take place.

The compressed air goes to the solenoid valve through flow control valve. The flow control valve is used to control the amount air flow to the cylinder. This flow is adjusted by manually by the tap is fixed above the flow control valve. Then this air goes to the 5/2 solenoid valve. The 5/2 solenoid valve is having one input port, two output port and two exhaust port.

The 5/2 solenoid valve is controlled by the electronic timing control unit. The speed of the on/off the solenoid valve is controlled by this timing control unit. The 2 outlet ports are connected to an actuator (Cylinder). The pneumatic activates is a double acting, single rod cylinder. The cylinder output is coupled to further purpose. The piston end has an air honing effect to prevent

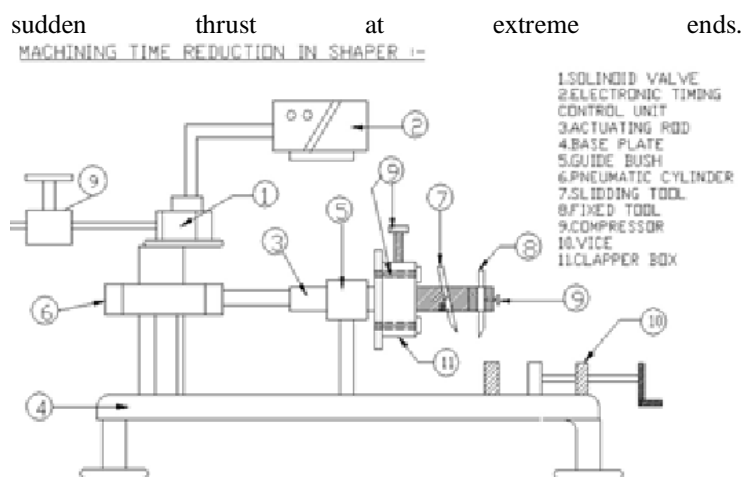

#### A. Principles of working

The compressed air from the compressor reaches the solenoid valve. The solenoid valve changes the direction of flow according to the signals from the timing device.

The compressed air pass through the solenoid valve and it is admitted into the front end of the cylinder block. The air pushes the piston for the cutting stroke. At the end of the cutting stroke air from the solenoid valve reaches the rear end of the cylinder block. The pressure remains the same but the area is less due to the presence of piston rod. This exerts greater pressure on the piston, pushing it at a faster rate thus enabling faster return stroke.

The screw attached is fixed to the clapper box frame gives constant loads which lower the sapper to enable continuous cutting of the work.

The stroke length of the piston can be changed by making suitable adjustment in the timer.

### V. CONCLUSION

Thus the machining time is reduced and quick response is achieved. The equipment is simple in construction and easy to maintain and repair. Cost of the unit is less when compared to other Machines. No fire hazard problem due to over loading. Comparatively the operation cost is less. The speed of forward and reverse stroke is varied. Continuous operation is possible without stopping

### VI. REFERENCES

1. Friedman, David (2006). ["No Light at the End of the Tunnel"](#). Los Angeles Times. New America Foundation. Retrieved 2007-05-12.
2. [Joseph, Keith](#) (1976). ["Monetarism Is Not Enough"](#). Center for Policy Studies. Margaret Thatcher Foundation. Retrieved 2007-05-12.
3. ["World oil supplies are set to run out faster than expected, warn scientists"](#). The Independent. June 14, 2007.
4. Manufacturing & Investment Around The World: An International Survey Of Factors Affecting Growth & Performance, ISR Publications/Google Books, revised second edition, 2002. [ISBN 978-0-906321-25-6](#).
5. Research, Industrial Systems (2002-05-20). [Manufacturing and Investment Around the World: An International Survey of Factors Affecting Growth and Performance](#). [ISBN 978-0-906321-25-6](#).
6. Bailey, David and Soyoung Kim (June 26, 2009). [GE's Immelt says U.S. economy needs industrial renewal](#). UK Guardian.. Retrieved on June 28, 2009.
7. Brookings Institution, [Why Does Manufacturing Matter? Which Manufacturing Matters?, February 2012](#)

8. ["Factory jobs: 3 million lost since 2000"](#). USATODAY.com. April 20, 2007.
9. ["Manufacturing, value added \(current US\\$\)"](#). access in February 20, 2013.
10. ["Manufacturing, value added \(current US\\$\) for EU and Eurozone"](#). access in February 20, 2013.

IJSER